



# Design and handling of surgical instrument transport cases

A guide on health  
& safety standards

December 2010

Working Across  
Borders

## Contents

INTRODUCTION .....	3
SCOPE .....	5
DEFINITIONS .....	6
DESIGN PRINCIPLES .....	7
Surgical instrument transport case .....	7
Recommended Design Specifications .....	8
Recommended Design Specifications .....	9
Slip sheets .....	10
Wheeled platform .....	10
Surgical instrument trays .....	12
SAFE USE AND HANDLING PRINCIPLES .....	13
Surgical Loan Kits Handling Process .....	14
Suppliers .....	15
Couriers .....	16
Hospitals .....	18
Equipment.....	20
Appendix 1 .....	23
PROCESS FOR SUPPLIERS - GENERAL INFORMATION .....	23
Process for suppliers – despatch .....	24
Process for suppliers – receipt .....	25
Appendix 2 .....	26
PROCESS FOR COURIERS - GENERAL INFORMATION .....	26
Process for couriers.....	27
Appendix 3.....	28
PROCESS FOR HOSPITALS - GENERAL INFORMATION .....	28
Process for hospitals – receipt .....	29
Process for Hospitals - despatch.....	30

## INTRODUCTION

The Heads of Workplace Safety Authority (HWSA) initiated a national intervention and compliance campaign in 2008 called 'The Safe Steps – Manual Handling, Slips and Trips in Hospitals Campaign'. It recommended a national focus for central sterilising supply departments (CSSDs), to ensure implementation of control measures that reduce the risks associated with manual tasks. It also recommended that particular attention be paid to the design of containers, handling of loan sets, use of lifting equipment, work area design, psychosocial issues, and liaison with equipment suppliers and building designers.

As a result of these recommendations, WorkCover NSW formed a national working party and undertook further research, which included state-wide inspections of CSSDs, courier services and surgical equipment suppliers. The inspections found that the transport and handling of road cases, tubs and surgical instrument trays presented a significant risk, with serious implications across these industry sectors.

This guide provides practical guidance for designers, manufacturers, suppliers, couriers and users of surgical instrument set transport cases, and outlines their obligations with regard to the transport and handling of the cases and their contents.

An industrial design expert was engaged to design a transport case that, when used in conjunction with this guide, would assist with national work health and safety legislative compliance.

**Contributors to this guide include:**

- Dr Lance Green
- ABC Couriers & Transport Services P/L
- Australian College of Operating Room Nurses (ACORN)
- Endeavour Couriers P/L
- Federation of Sterilising Research and Advisory Council of Australia (FSRACA)
- Golden Messenger Transport
- Johnson and Johnson Medical P/L
- Knox Private Hospital Victoria
- Medtronic Australasia P/L
- Messenger Post Couriers
- Northern Sydney Central Coast Area Health Service (NSCCAHS)
- NSW Operating Theatre Association (OTA)
- Queensland Health
- Smartline Machinery P/L
- Smartways Logistics
- Smith & Nephew Surgical P/L
- Sterilising Research and Advisory Council of Australia (SRACA) (NSW & VICTORIA)
- Stryker Australia P/L
- Sydney South West Area Health Service (SSWAHS)
- Synthes Australia P/L
- TNT Express
- TOLL Priority
- Zimmer P/L

## SCOPE

This guide provides advice on the design, manufacture, supply, transportation and use of surgical instrument transport cases and their contents, with a particular emphasis on the safe design aspect. The handling of this equipment is addressed through workplace design and practices, from the designer through to the end-user in the hospital. It also addresses the obligations of duty holders who are associated with the handling of these cases and their contents.

Surgical instrument trays less than 300mm long are not required to be transported in the surgical instrument set cases described in this guide.

DRAFT

## DEFINITIONS

**Consignment sets/long-term loaners** - surgical instrument sets and implant prosthesis sets that are owned by the supplier and remain at the hospital on long-term contract.

**Road case** - a wheeled case that is currently used to house surgical instrument sets and / or medical supplies for transportation. (Under the new system as described in this industry guide these cases will be phased out and replaced by the new surgical instrument transport case)

**Slip sheet** - a slip sheet is a divider between the trays that facilitates easy removal / insertion of contents.

**Surgical instrument inner tray** - a tray that contains surgical instruments, which is usually housed in an outer container.

**Surgical instrument outer container** – a container that houses the inner surgical instrument trays.

**Surgical instrument set** - a set of instrument trays used in surgical operations.

**Surgical loan kit** - a combination of fully-laden surgical instrument transport cases and tubs for loan to hospitals for a surgical operation – the kits are typically returned to suppliers after surgery, unless on long-term consignment.

**Surgical instrument transport case (new case as described in this guide)** - a case used to house surgical instrument sets and / or medical supplies for transportation.

**Tub** - a top-opening container that is used to house surgical instrument sets and / or medical supplies for transportation. (Under the new system as prescribed in this industry guide tubs will only be used to house surgical implants)

**Wheeled platform** - a dolly, or other wheeled platform, for moving surgical instrument set cases and tubs.

## DESIGN PRINCIPLES

Work health and safety legislation places obligations on designers to identify hazards and control the risks associated with the design, manufacture, supply and use of equipment. The designer must, where reasonably practicable, design-out any risks associated with the use, handling and transportation of the following equipment.

### Surgical instrument transport case

The surgical instrument transport case used to transport surgical instrument trays and medical supplies should be strong, durable and made from lightweight weatherproof material that minimises the potential for contamination. The case should protect the contents and minimise liquids, dust and contaminants from entering the case. The external and internal surfaces should be easy to clean and maintain.

The case should be designed to:

- be end-opening for improved access when packing and unpacking trays and aligned to open in the same direction – doors and associated locking mechanisms should allow clear and easy access to the contents of the case and ensure the contents are secure during transportation
- be securely stacked and transported on an appropriately designed wheeled platform
- allow a tub to be securely stacked on top during handling and transportation
- allow suitable signage and labelling to be prominently displayed
- allow a mechanical aid to raise a single case or stack to a suitable working height.
- allow trays and associated equipment to be removed and inserted without lifting, excessive force or awkward posture
- allow slip sheets to be located between trays and securely retained within the case.

Recommended Design Specifications

SURGICAL INSTRUMENT TRANSPORT CASE  
ASSEMBLED COMPONENTS

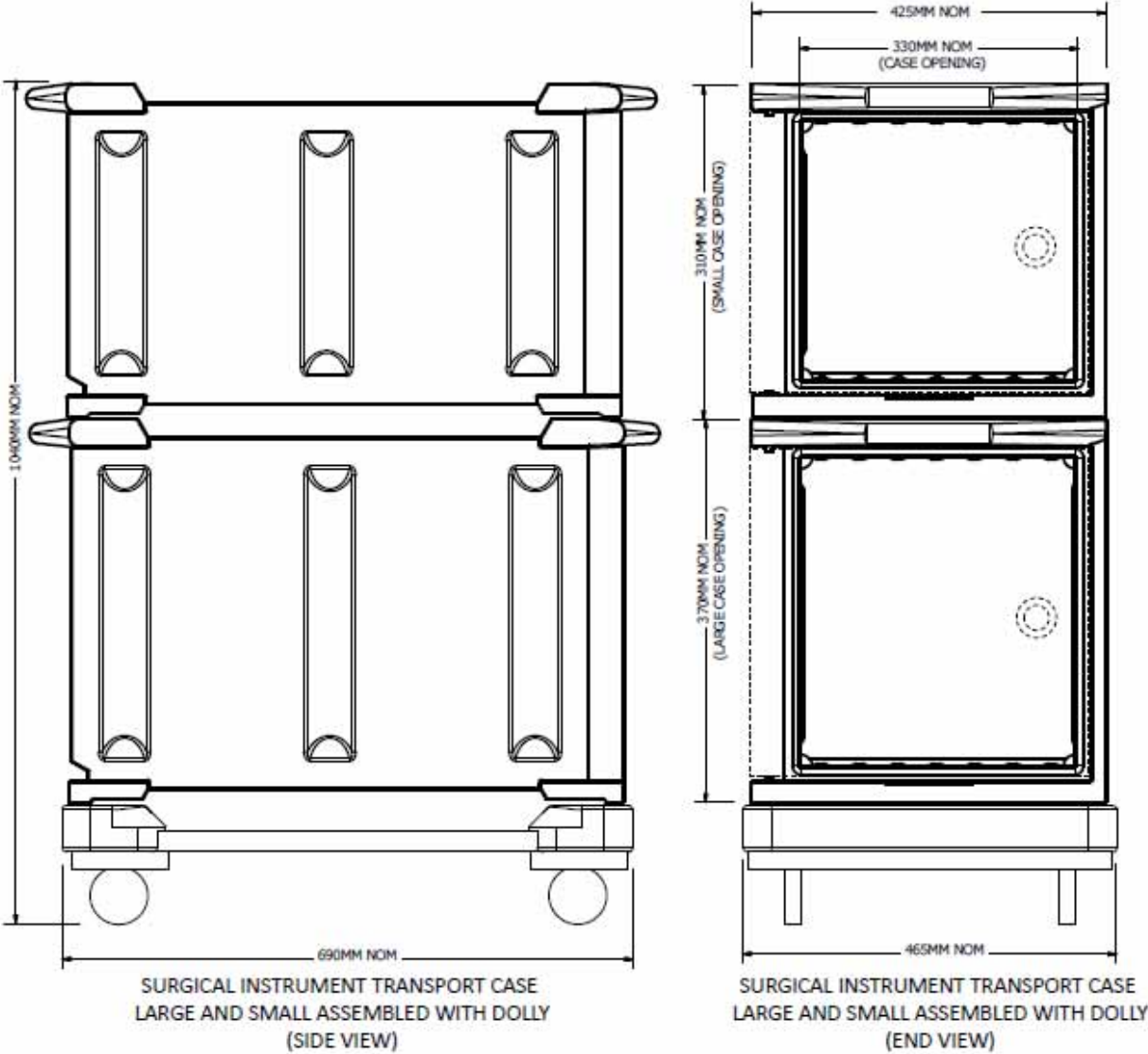

Recommended Design Specifications

SURGICAL INSTRUMENT TRANSPORT CASE  
INDIVIDUAL COMPONENTS

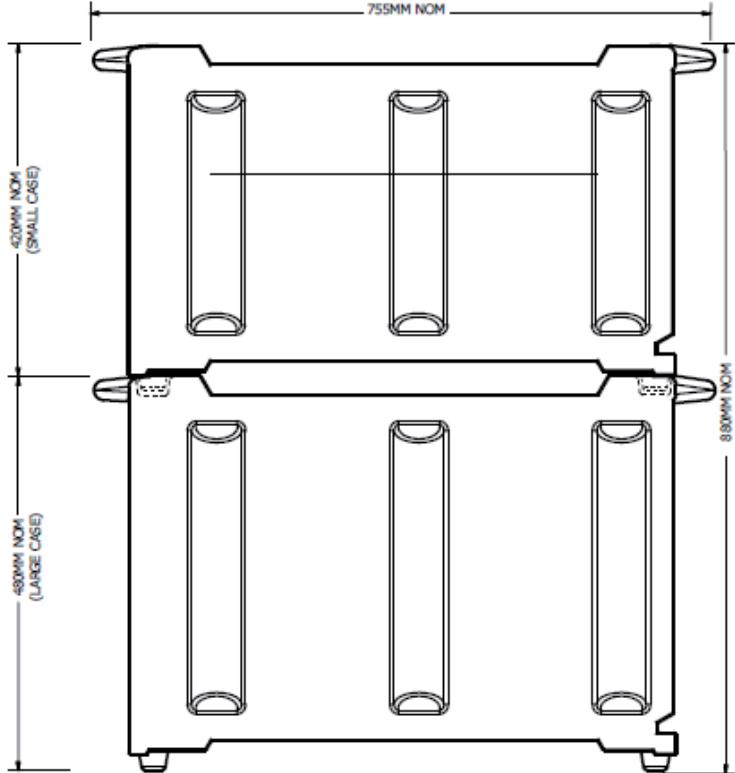

SURGICAL INSTRUMENT TRANSPORT CASE  
LARGE AND SMALL ASSEMBLED  
(SIDE VIEW)

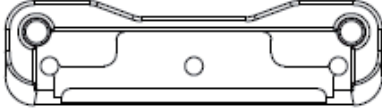

BUMPER AND CASE DETAILING  
TO ACCOMMODATE TUB FOOTING

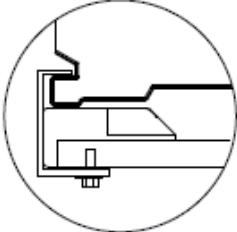

METHOD OF FASTENING  
CASE TO DOLLY

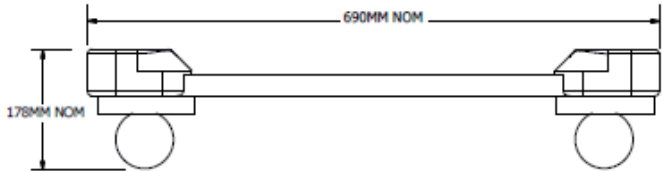

SURGICAL INSTRUMENT TRANSPORT CASE  
DOLLY  
(SIDE VIEW)

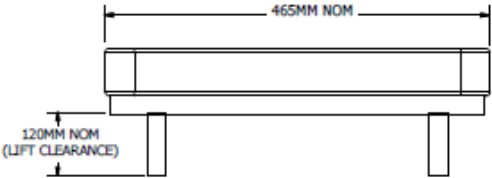

SURGICAL INSTRUMENT TRANSPORT CASE  
DOLLY  
(END VIEW)

**Figure 1a - Prototype case and platform**



**Figure 1b - Prototype case with slip sheets**



### **Slip sheets**

Slip sheets should be made of a material that is easy to clean and minimises friction. They should be located between trays and securely retained within the case yet able to be removed when required.

### **Wheeled platform**

The wheeled platform used to move cases and tubs should be strong, durable and made from lightweight weatherproof material that minimises the potential for contamination.

The platform should be designed to:

- be easy to clean and maintain
- allow for secure location of the stacked cases and tubs on top of the platform
- ensure the stack is stable and secure when moved
- allow locking to the bottom case where required
- allow a mechanical aid to raise the wheeled platform and stack of cases to a suitable height
- allow a mechanical aid to raise a single case or cases from the platform where required
- support the maximum safe working load of the stack.

The platform should have at least two multi-directional wheels, to ensure ease of movement and steering. The wheels should include a braking mechanism and should conform to relevant standards. To determine the most appropriate wheels, consider the following factors:

- terrain
- durability
- vibration
- manoeuvrability
- safety

**Figure 2a & b - Prototype wheeled platform (dolly)**



**Figure 3a - A multi-directional wheel**



**Figure 3b - A fixed wheel**

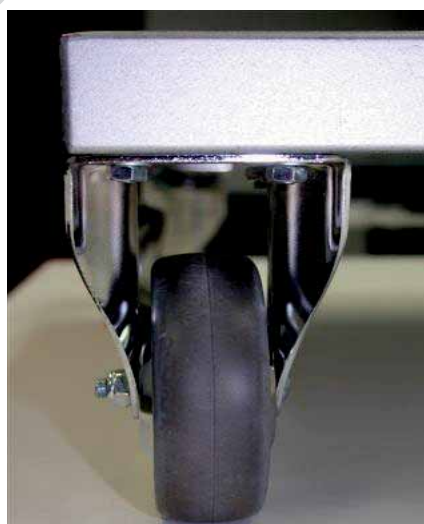

## Surgical instrument trays

Surgical instruments fit into specifically designed surgical instrument inner trays which are frequently housed in surgical instrument outer containers. The majority of Australian suppliers do not necessarily have control over the design of trays and containers, however where reasonably practicable, the design principles set out in this guide should be followed.

Trays and containers protect instruments from damage during transportation and set out the instruments in a logical manner for surgery. They should be made from lightweight, durable material that can be cleaned and sterilised, should fit into an end-opening case and be easy to remove.

Tray and container handles should be designed to:

- allow fully-laden trays to be safely handled
- withstand sterilisation
- retain structural integrity
- be easily accessible when trays and containers are inserted or removed from the case.

This guide recommends that fully laden individual trays, where reasonably practicable, should not exceed 7 kg.

**Figure 4a - Surgical instrument inner trays**   **Figure 4b - Surgical instrument outer containers**



## SAFE USE AND HANDLING PRINCIPLES

In addition to the loan kit area being designed to eliminate or minimise manual tasks, every activity involved in the handling of surgical loan kits must be evaluated by each facility with action taken to eliminate or minimise the risks associated with all hazardous manual tasks. This will assist with safer, more efficient and cost-effective work processes.

All equipment should conform to relevant work health and safety legislation, this guide or an equivalent level of safety. Information regarding the safe use and handling of kits should be provided at the point of supply/use. Equipment should be regularly inspected and maintained to ensure it is able to be used in a safe and appropriate manner as set out in this guide.

Communication strategies should be in place to minimise the number of manual tasks and ensure safe work procedures are effective. A systematic process should exist between suppliers, couriers and hospitals regarding the status of kits. The process should include:

- coordinated receipt/delivery protocols (how, when and where)
- appropriate contacts, internally and externally
- suitable mechanical-handling equipment that is available at all points of the process
- effective delivery and scheduling contractual conditions

A surgical loan kit handling process flowchart has been developed to provide a step by step overview of all activities involved in this process (see next page). In addition, tools have been developed to support key work processes for suppliers, couriers and hospitals and are available as appendices.

- Process for Suppliers – Appendix 1 ([Link](#))
- Process for Couriers – Appendix 2 ([Link](#))
- Process for Hospital – Appendix 3 ([Link](#))

## Surgical Loan Kits Handling Process

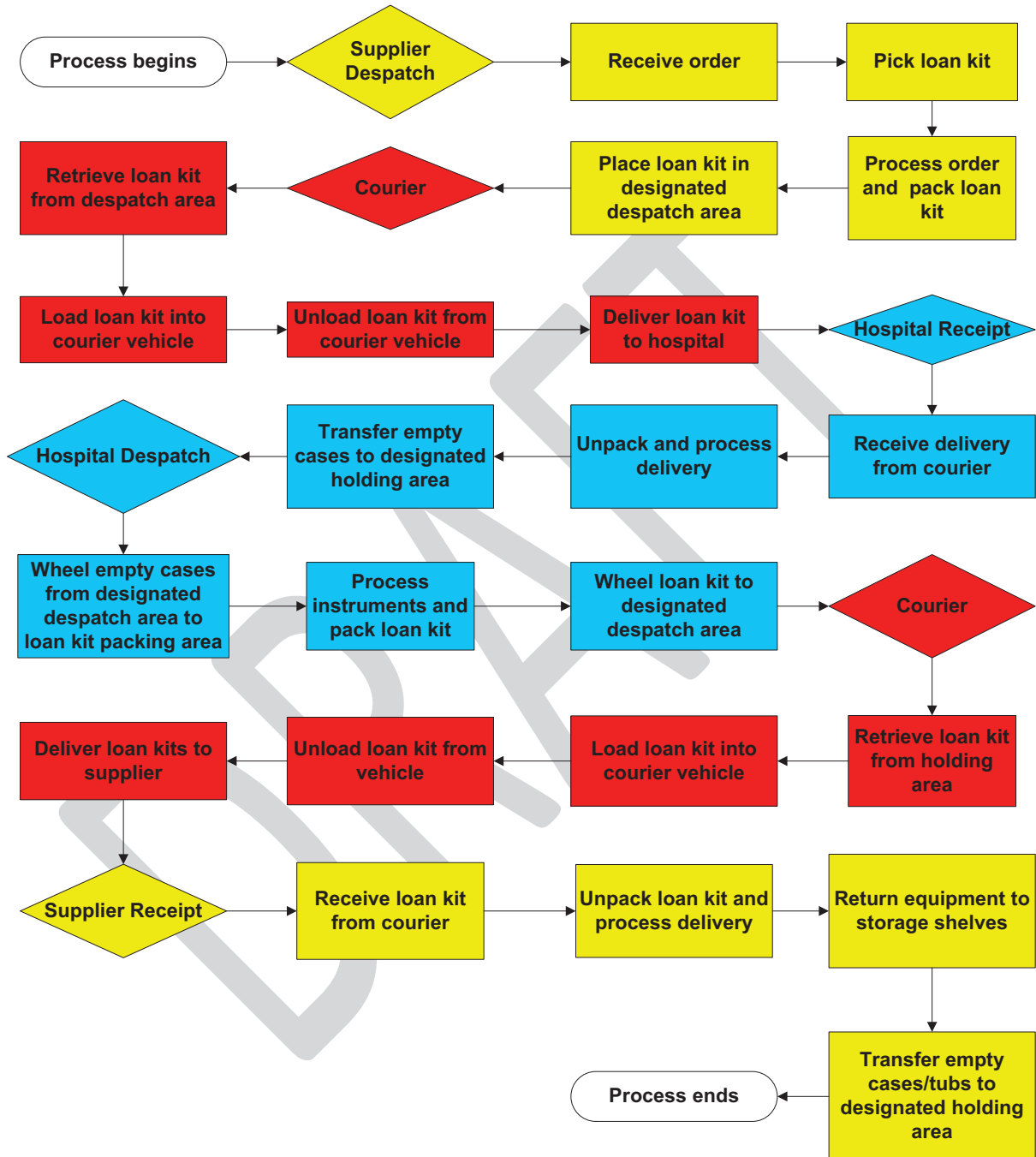

Legend	
Supplier	Yellow
Courier	Red
Hospital	Blue

## Suppliers

As a supplier, designate a person to be responsible for coordinating the loan kit handling process. Document procedures for all tasks related to the handling and processing of kits, and ensure all procedures follow health, safety and hygiene standards.

Effective communication is essential when coordinating the receipt and despatch of kits. Prepare a schedule of all receipts and despatches that includes the number of deliveries and the type of kits used, together with appropriate contact details for the hospitals and couriers.

Loaded trays should not exceed 7 kg and a stack of loaded cases should not exceed 80kg. Stacked cases and tubs should not exceed 1350mm high and cases should always remain on their platform. Store them in a safe and secure place when not in use.

Use clear, self-explanatory signs and display them prominently on the side of each case – include your company name, the gross weight of each case, and any other relevant information. Ensure the case carrying the loan kit documentation is clearly identified. Remove old signs and labels.

The loan kit area should be configured to eliminate or minimise the risks associated with manual tasks. This should include:

- a designated area with adequate floor space for the systematic packing / unpacking of kits, including the manoeuvring of lifters and associated mobile equipment.
- designated holding and storage areas with adequate floor space
- adequate access and egress with level non-slip floor surfaces
- a work area that optimises work flow and minimises lifting and double handling
- mechanical lifters and height adjustable work benches with fitted rollers
- Mobile equipment to assist with equipment handling and movement

## Couriers

As a courier ensure you follow safe working procedures when loading and unloading your vehicle. Ensure that:

- vehicles are fit for purpose
- loads are safely secured
- mechanical aids are fitted to vehicles eg. tailgate lifters. Where this is not reasonably practical, use mobile lifters and ramps
- stacks are kept in their original configuration

Ensure that contractual arrangements are in place with all other parties. These arrangements should include:

- a stipulation that transport cases are not manually lifted in/out of courier vehicles
- designated loading and unloading areas
- timely and effective despatch and receipt procedures
- designated delivery and collection points





This modified vehicle has a floor and tailgate which lowers to the ground to enable loads to be wheeled on and off via the ramp.

This type of vehicle will eliminate the need to manually lift cases during loading and unloading.



### Ramps / Skids

When purchasing ramp or skids ensure that:

- the length and width allow for safe loading and unloading of kits.
- the weight does not pose a risk
- they can be fitted and removed easily
- they allow safe and smooth transition of kits when loading / unloading vehicle
- they are stable and secure when in use
- they can be stored and secured in the vehicle when not in use

## Hospitals

As a hospital you should ensure that the CSSD manager designates a staff member to be responsible for coordinating the loan kit handling process. Safe operating procedures should be in place and displayed clearly for all tasks related to the handling and processing of kits. All procedures should follow health, safety and hygiene standards.

Designated areas should be provided for the receipt/despatch of kits with adequate work space allocated to pack and unpack the kits. Cases should remain on their platform at all times for ease of handling and transportation and should be stored in a safe and secure area when not in use.

Effective communication is essential when coordinating the receipt and despatch of kits. This should include receipt/despatch schedules, number of deliveries and type of kits being used along with appropriate contact details for suppliers and couriers. Hospitals should ensure that kits are returned in a similar configuration and in line with designated weight restrictions.

The loan kit area should be configured to eliminate or minimise the risks associated with manual tasks. This should include:

- a designated area with adequate floor space for the systematic packing / unpacking of kits, including the manoeuvring of lifters and associated mobile equipment.
- designated holding and storage areas with adequate floor space
- adequate access and egress with level non-slip floor surfaces
- a work area that optimises work flow and minimises lifting and double handling
- mechanical lifters and height adjustable work benches with fitted rollers
- Mobile equipment to assist with equipment handling and movement

Further information for hospitals on recommended floor areas can be found in the 'Australasian Health Facility Guidelines Revision V 3.0 (15<sup>th</sup> May 2009), Part B – Health Facility Briefing and Planning – Appendices - Schedule of Accommodation, pages 302-305'.

Diagrams illustrate recommended layouts for handling surgical loan kits in hospitals



## Equipment

Seek advice from a competent person to ensure that equipment is fit for purpose and consider the following. Equipment should be tested prior to purchase.

	<p><b>Mobile Lifter</b></p> <p>When purchasing a mobile lifter, ensure that it is compatible with the work environment, fit for purpose and:</p> <ul style="list-style-type: none"><li>• has a lifting plate / tines that do not deflect more than 2mm when under load</li><li>• manoeuvres easily in a restricted workspace</li><li>• does not create further risk when operated</li><li>• has a safe working load of 100kg or greater</li><li>• has appropriate castors, with braking capacity</li><li>• accesses the platform directly from floor level</li><li>• lifts to at least 1000mm above floor level</li></ul>
	<ul style="list-style-type: none"><li>• has a smooth and efficient action, with a powered lift mechanism that is easily accessible</li><li>• lifts / lowers stack securely and safely</li><li>• can lift a single case or tub when required</li><li>• can be easily cleaned</li></ul>



### **Fixed Lifter**

When purchasing a fixed lifter, ensure that it is compatible with the work environment, fit for purpose and:

- has a lifting plate / tines that do not deflect more than 2mm when under load
- does not create further risk when operated
- has a safe working load of 100kg or greater
- can be fixed to a wall or mounting frame
- accesses the platform directly from floor level
- lifts to at least 1000mm above floor level
- has a smooth and efficient action, with a powered lift mechanism that is easily accessible
- lifts / lowers stack securely and safely
- is easily cleaned



### **Adjustable Work Bench**

When purchasing an adjustable work bench, ensure that it is compatible with the work environment, fit for purpose and:

- can accommodate multiple instrument trays
- can be adjusted between 750mm and 1150mm from floor level
- has rollers fitted at loading and unloading points
- has an abrasion-resistant, non-porous work surface
- has a solid work surface
- is easy to clean

The work bench should be located close to the lifter and with space to allow trolleys to manoeuvre nearby.



### **Rollers**

Rollers should be fitted to work benches to enable smooth transfer of instrument trays and can be removable.



### **Transport Trolley**

When purchasing a transport trolley ensure that it is compatible with the work environment, fit for purpose and:

- shelving correlates to height adjustable Table
- where reasonably practicable the trolley can be height adjusted
- there is sufficient space to store instrument trays
- is easily cleaned
- has no sharp edges

## Appendix 1

### PROCESS FOR SUPPLIERS - GENERAL INFORMATION

The new surgical instrument transport case (case), described in the *National Guide – Design and Handling of Surgical Instrument Transport Cases* (the Guide) is designed to be securely stacked on a platform (or equivalent) to enable them to be wheeled and easily manoeuvred. The design of tubs is not addressed within the scope of the National Guide. Tubs should only be used to transport prostheses and / or other lightweight surgical equipment. It is essential that tubs are loaded / unloaded and handled using appropriate manual handling techniques. Loaded cases should remain on their platform at all times for ease of use and movement. Tubs can be placed on top of a stack of cases during handling and transport. Each stack of loaded cases/tubs should measure a maximum height of 1350 mms and should not exceed 80kg. The gross weight of each case and tub must be displayed.

When planning safe systems of work you should consider the following:

1. a) Plan the layout of the warehouse to allow for an efficient process flow, in particular the designated:
  - loan kit receipt area
  - loan kit processing area
  - loan kit despatch area
  - loan kit holding area – with designated space to store stacked empty cases (2 – 3 high max) and empty tubs.
  - instrument tray storage area
- b) Ensure the designated loan kit despatch and receipt areas are easily accessible to both workers and couriers.
2. When deliveries consist of a single case only, appropriate manual handling principles must be adhered to (e.g. use a hand truck or similar).
3. Ensure there is a stipulation in place in courier's contract that transport cases are not manually lifted in/out of courier vehicle.

## Process for suppliers – despatch

Process	Considerations
1. Receive order	
2. Pick loan kit	<p><b>Shelving</b></p> <ul style="list-style-type: none"> <li>• Allow adequate space between shelving to allow unrestricted movement</li> <li>• Locate heavy and frequently used trays at waist height</li> <li>• Locate lighter trays on higher and lower shelves</li> </ul> <p><b>Trolley</b></p> <ul style="list-style-type: none"> <li>• Use a trolley when picking equipment from warehouse shelving</li> <li>• Ensure trolley is height adjustable, or at individuals waist height</li> <li>• Use appropriate manual handling techniques when handling trays</li> </ul>
<p><b>3. Process order and pack loan kit:</b></p> <ul style="list-style-type: none"> <li>• Slide trays onto workbench</li> <li>• Check trays against original order (follow QA procedures).</li> <li>• Ensure the correct number of cases/tubs are prepared for the order</li> <li>• Ensure cases are safely stacked and secured to platform/s.</li> <li>• Wheel platform loaded with stacked empty cases onto a fixed or mobile lifter.</li> <li>• Use lifter to raise/lower cases so that individual trays are loaded at bench height</li> <li>• Slide trays into case using slip sheets to separate trays. Repeat until each case is full.</li> <li>• Enclose all relevant documentation within case.</li> <li>• Securely lock and label each transport case.</li> </ul>	<p><b>Workbench</b></p> <ul style="list-style-type: none"> <li>• Ensure the workbench is height adjustable to allow for various heights of employees</li> <li>• Check area around workbench and lifter are free of trip hazards.</li> <li>• It is recommended that a roller is fitted to the end/s of the workbench to allow trays to slide easily into the case</li> <li>• Ensure surface area of workbench allows adequate space for safe work and QA procedures to be followed</li> </ul> <p><b>Lifter</b></p> <ul style="list-style-type: none"> <li>• Use a mechanical lifter (fixed or mobile) to move/raise/lower cases and tubs.</li> <li>• Consider process flow and available floor space to determine which lifter would be most appropriate (fixed or mobile)</li> </ul>
4. Place loan kit in designated despatch area	<p><b>Loan Kit Despatch Area</b></p> <ul style="list-style-type: none"> <li>• Ensure floor surface allows unrestricted movement of workers and equipment.</li> <li>• Ensure area is free of trip hazards.</li> </ul>

## Process for suppliers – receipt

Process	Considerations
<p><b>1. Receive loan kit from courier</b></p> <ul style="list-style-type: none"> <li>• Instruct courier to wheel cases/tubs to designated receipt area.</li> </ul> <p><b>2. Unpack loan kit and process delivery</b></p> <ul style="list-style-type: none"> <li>• Wheel stack into loan kit process area and onto fixed or mobile lifter.</li> <li>• Raise/lower lifter so that tray (to be unloaded from case) is at bench height.</li> <li>• Pull tray from case and slide onto workbench.</li> <li>• Check trays against original order (follow QA procedures).</li> <li>• Repeat process for each tray until case is empty.</li> <li>• Remove any unnecessary labelling and wheel to designated holding area.</li> </ul>	<p><b>Loan Kit Area</b></p> <ul style="list-style-type: none"> <li>• Ensure floor surface allows unrestricted movement of workers and equipment.</li> <li>• Ensure area is free of trip hazards.</li> </ul> <p><b>Lifter</b></p> <ul style="list-style-type: none"> <li>• Use a mechanical lifter to raise and lower cases.</li> <li>• Consider process flow and available floor space to determine which lifter would be most appropriate (fixed or mobile).</li> </ul> <p><b>Workbench</b></p> <ul style="list-style-type: none"> <li>• Ensure workbench is height adjustable to allow for various heights of employees.</li> <li>• Ensure surface area allows adequate space for safe work and QA procedures to be followed</li> <li>• It is recommended that a roller is fitted to the end/s of the workbench to allow trays to slide easily out of the case</li> <li>• Use appropriate manual handling techniques when handling trays.</li> </ul>
<p><b>3. Return equipment to storage shelves.</b></p>	<p><b>Shelving</b></p> <ul style="list-style-type: none"> <li>• Allocate adequate room between shelving to allow unrestricted movement.</li> <li>• Locate heavier and frequently used trays at waist height.</li> <li>• Locate lighter trays on higher and lower shelves.</li> </ul> <p><b>Trolley/Aid</b></p> <ul style="list-style-type: none"> <li>• Use a trolley / aid when returning equipment to warehouse shelving</li> <li>• Ensure trolley / aid corresponds to the height of the workbenches</li> <li>• Use appropriate manual handling techniques when returning trays to shelving.</li> </ul>
<p><b>4. Transfer empty cases/ tubs to designated holding area.</b></p>	<p><b>Holding area</b></p> <ul style="list-style-type: none"> <li>• Ensure floor surface allows for unrestricted movement of workers and equipment</li> <li>• Ensure area is free of trip hazards.</li> </ul>

## Appendix 2

### PROCESS FOR COURIERS - GENERAL INFORMATION

The new surgical instrument transport case (case), described in the *National Guide – Design and Handling of Surgical Instrument Transport Cases* (the Guide) is designed to be securely stacked on a platform (or equivalent) to enable them to be wheeled and easily manoeuvred.

The design of tubs is not addressed within the scope of the National Guide. Tubs should only be used to transport prostheses and/or other lightweight surgical equipment. It is essential that tubs are loaded / unloaded and handled using appropriate manual handling techniques. Loaded cases should remain on their platform at all times for ease of use and movement. Tubs can be placed on top of a stack of cases during handling and transport. Each stack of loaded cases/tubs should measure a maximum height of 1350 mms and should not exceed 80kg.

When deliveries consist of a single case only, appropriate manual handling principles must be adhered to (e.g. use a hand truck or similar)

Couriers should ensure:

- their vehicles are fit for purpose
- all loads are safely secured and restrained during transportation
- mechanical aids such as tailgate lifters or similar should be fitted to the vehicle and where this is not reasonably practical appropriate aids (i.e. mobile lifters and ramps) should be used
- the stacks are kept in their original configuration when delivered

Contractual arrangements covering the safe collection and delivery of kits should be in place with all parties. These arrangements should include:

- designated vehicle loading and unloading areas;
- timely and effective despatch and receipt procedures;
- designated delivery and collection points

## Process for couriers

Process	Considerations
<p><b>1. Retrieve loan kit from despatch area:</b></p> <ul style="list-style-type: none"> <li>● Park vehicle in designated loading zone or as close to hospital/supplier designated loan kit holding area as possible.</li> <li>● Retrieve kits from designated area.</li> <li>● Check total number of cases and tubs against documented order.</li> <li>● Ensure each case is correctly locked and secured prior to leaving the designated holding area</li> <li>● Ensure tubs have lids closed.</li> <li>● Ensure all kits are appropriately labelled.</li> <li>● Wheel kits to courier vehicle.</li> </ul>	<p><b>Delivery Route</b></p> <ul style="list-style-type: none"> <li>● When parking the vehicle, consider the ground/ floor surface between the vehicle and pick up point at each destination</li> <li>● Have a set route (as direct as possible) between the vehicle and the pick up point at each destination</li> </ul>
<p><b>2. Load loan kits into courier vehicle</b></p> <ul style="list-style-type: none"> <li>● Load kits into the courier vehicle by means other than physically lifting. .</li> <li>● Ensure all kits are appropriately secured for travel in courier van.</li> </ul>	<p><b>Courier Equipment</b></p> <p>The cases and platform are designed so that physical lifting and lowering of items is not required. It is recommended that any of the following aids are used to load and unload the stack/s into the vehicle:</p> <ul style="list-style-type: none"> <li>- Tailgate lifter</li> <li>- A fixed, hydraulic fold out ramp</li> <li>- A set of lightweight skids</li> <li>- A lightweight portable foldable ramp</li> <li>- A mobile lifter supplied by the supplier/hospital</li> </ul>
<p><b>3. Unload loan kits from courier vehicle</b></p> <ul style="list-style-type: none"> <li>● Remove vehicle restraints</li> <li>● Ensure each case remains locked and secured to platform before unloading from vehicle.</li> <li>● Unload kits out of vehicle by means other than physically lifting.</li> </ul>	
<p><b>4. Deliver loan kits to hospital/supplier.</b></p> <ul style="list-style-type: none"> <li>● Park vehicle in designated area, or as close to the hospital/supplier designated loan kit area as possible</li> <li>● Wheel cases to designated loan kit receipt area in CSSD/supplier warehouse</li> <li>● Check total number of cases against documented order.</li> </ul>	<p><b>Delivery Route</b></p> <ul style="list-style-type: none"> <li>● When parking the vehicle, consider the ground / floor surface between the vehicle and drop off point at each destination</li> <li>● Have a set delivery route (as direct as possible) between the vehicle and the drop off point at each destination</li> </ul>

## Appendix 3

### PROCESS FOR HOSPITALS - GENERAL INFORMATION

The surgical instrument transport case (case), described in the *National Guide – Design and Handling of Surgical Instrument Transport Cases* (the Guide) is designed to be securely stacked on a platform (or equivalent) to enable them to be wheeled and easily manoeuvred.

The design of tubs is not addressed within the scope of the National Guide. Tubs should only be used to transport prostheses and / or other lightweight surgical equipment. It is essential that tubs are loaded / unloaded and handled using appropriate manual handling techniques. Loaded cases should remain on their platform at all times for ease of use and movement. Tubs can be placed on top of a stack of cases during handling and transport. Each stack of loaded cases/tubs should measure a maximum height of 1350 mms and should not exceed 80kg.

When planning safe systems of work you should consider the following:

3. a) Plan the layout of the loan kit area to allow for an efficient process flow, in particular the designated:
  - loan kit receipt area
  - loan kit processing area
  - loan kit despatch area
  - loan kit holding area – with designated space to store stacked empty cases (2 – 3 high max) and empty tubs
  - Instrument tray storage area.
- b) Ensure the designated loan kit despatch and receipt areas are easily accessible to both workers and couriers.
4. When deliveries consist of a single case only, appropriate manual handling principles must be adhered to (e.g. use a hand truck or similar).
5. It is recommended that a stipulation is in place in the courier's contract that cases and tubs are not manually lifted in/out of courier vehicle.
6. It is recommended that internal/external processes are in place to ensure equipment for routine elective surgery arrives at least 24 hours prior to the start of that surgery.

## Process for hospitals – receipt

Process	Considerations
<p><b>1. Receive delivery from courier.</b></p> <ul style="list-style-type: none"> <li>• Instruct courier to wheel kits to designated receipt area.</li> </ul> <p><b>2. Unpack and process delivery</b></p> <ul style="list-style-type: none"> <li>• Wheel kits into loan kit processing area and onto fixed or mobile lifter</li> <li>• Raise / lower lifter so that tray (to be unloaded from case) is at bench height.</li> <li>• Pull tray from case and slide onto workbench.</li> <li>• Check trays against original order (following QA procedures).</li> <li>• Transfer trays and required instruments to trolley/s for transfer to sterilisation process.</li> <li>• Repeat process for each tray until case is empty.</li> <li>• Remove any unnecessary labelling.</li> </ul>	<p><b>Loan Kit Area</b></p> <ul style="list-style-type: none"> <li>• Ensure designated loan kit receipt area can be easily accessed by couriers and employees.</li> <li>• Ensure floor surface allows unrestricted movement of workers and equipment</li> <li>• Ensure area is free of trip hazards.</li> <li>• Ensure that slip-sheets remain in case at all times.</li> </ul> <p><b>Lifter</b></p> <ul style="list-style-type: none"> <li>• Use a mechanical lifter to raise and lower cases.</li> <li>• Consider process flow and available floor space to determine which would be the most appropriate (fixed or mobile).</li> </ul> <p><b>Workbench / Trolley</b></p> <ul style="list-style-type: none"> <li>• Ensure workbenches are height adjustable to allow for various heights of employees</li> <li>• Ensure surface area allows adequate space for safe work and QA procedures to be followed</li> <li>• It is recommended that a roller is fitted to the end/s of workbench to allow trays to slide easily out of the case</li> <li>• Use appropriate manual handling techniques when handling trays</li> <li>• Ensure trolley shelves correspond to the height of the workbenches</li> </ul>
<p><b>3. Transfer empty cases to designated holding area.</b></p>	<p><b>Holding area</b></p> <ul style="list-style-type: none"> <li>• Ensure floor surface allows unrestricted movement of workers and equipment</li> <li>• Ensure area is free of trip hazards.</li> </ul>

## Process for Hospitals - despatch

Process	Considerations
<p><b>1. Wheel empty cases from designated holding area to loan kit packing area</b></p>	<p><b>Loan Kit Area</b></p> <ul style="list-style-type: none"> <li>• Ensure floor surface area allows unrestricted movement of workers and equipment.</li> <li>• Ensure area is free of trip hazards.</li> </ul> <p><b>Workbench / Trolleys</b></p> <ul style="list-style-type: none"> <li>• Ensure workbenches are height adjustable to allow for various heights of employees</li> <li>• Ensure trolley shelves correspond to the height of the workbenches</li> <li>• Ensure area around workbench and trolleys are free of trip hazards.</li> <li>• It is recommended that a roller is fitted to the end/s of the workbench to allow trays to slide easily into the case</li> <li>• Ensure sufficient surface area of workbench allows adequate space for safe work and QA procedures to be followed.</li> </ul> <p><b>Lifter</b></p> <ul style="list-style-type: none"> <li>• Use a mechanical lifter (fixed or mobile) to move/raise and lower cases.</li> <li>• Consider process flow and available floor space to determine which lifter would be most appropriate (fixed or mobile).</li> </ul>
<p><b>2. Process instruments and pack loan kit :</b></p> <ul style="list-style-type: none"> <li>• Once internal sterilisation process has taken place, transfer trays and instruments onto workbench</li> <li>• Wheel platform loaded with stacked empty cases onto the fixed or mobile mechanical lifter.</li> <li>• Use lifter to raise / lower cases so that individual trays are loaded at bench height</li> <li>• Slide trays into case using slip sheets to separate trays.</li> <li>• Repeat process until case is full.</li> <li>• Enclose all relevant documentation within case.</li> <li>• Securely lock and label each case.</li> </ul>	
<p><b>3. When loan kit to designated despatch area.</b></p>	<p><b>Loan Kit Despatch Area</b></p> <ul style="list-style-type: none"> <li>• Ensure area can be easily and safely accessed by couriers and employees.</li> <li>• Ensure floor surface allows unrestricted movement for workers and equipment</li> <li>• Ensure area is free of trip hazards.</li> </ul>